

# MV DISCONNECT SWITCH

- 900A, SINGLE INSULATOR, MARINE GRADE

## The best Single Insulator Disconnect Switch, suitable for all MV applications in NZ

Aluma-Form, Inc. specialises in innovative, custom-engineered overhead utility and communications solutions. Aluma-Form's reputation for excellence is based on over a 60-year history of manufacturing high-quality, cost-effective products with a superior working life.

The NEMA mounted Single Insulator Hookstick Disconnect Switch range is perfect for the harsh, high pollution New Zealand environment and the marine grade option offers even greater protection.

### KEY FEATURES

- 2 parts 11/22 and 33kV applications
- Both rated up to 900A
- 125kV BIL for the up to 27kV model & 150kV BIL for the up to 35kV model
- Insulator material: Silicone polymer
- Includes brass earth spigot – for temporary earth stick placement
- Light weight
- Easy to install and operate
- Testing is in accordance with IEEE C37.34
- Blade is silver-plated copper
- Large formed galvanised steel load buster hook
  - Optimally positioned for easy loadbuster tool attachment and removal after opening
  - Stronger than castings
- Contact & hinge are silver-plated brass
- Use of 316 stainless steel and silicon bronze fitting where possible provide high corrosion resistance – hence the marine grade classification

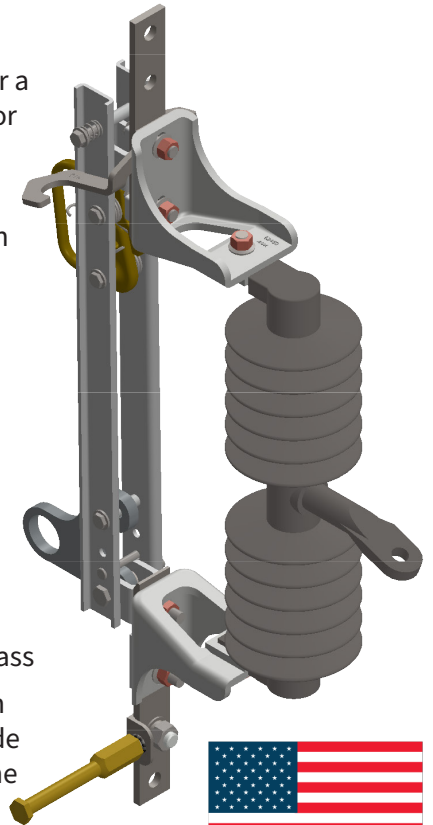

MADE IN USA

### TECHNICAL SPECIFICATIONS

HDS	900A	- SI	27	S	- 125	N	B	M
Disconnect Switch	Amperage Rating	Switch Type	Insulation Rating	Insulator Material	Insulator BIL Rating	Bracket Style	Bracket	Corrosion Level
	<b>900A</b>	<b>SI</b> -Single Insulator	<b>27</b> - 11-22kV <b>35</b> - up to 38kV	<b>S</b> - Silicone	<b>125</b> - 125kV BIL (27 model only) <b>150</b> - 150kV BIL (35 model only)	<b>N</b> - NEMA	<b>B</b> - Bracket	<b>M</b> - Marine Grade (316SS & Si Bronze Hdwe, Tin Plated Al Mounts, 316SS Insulator Terminals)

### ORDERING INFORMATION

CAT No.	Voltage	BIL Rating	Description
HDS900A-SI27S-125NBM	11-22KV	125KV	SINGLE INSULATOR DISCONNECT SWITCH, 900A, SILICONE INSULATOR, MARINE GRADE C/W NEMA B BRACKET
HDS900A-SI38S-150NBM	UP TO 38KV	150KV	

**DIMENSIONS - HDS900A-SI27S-125NBM**

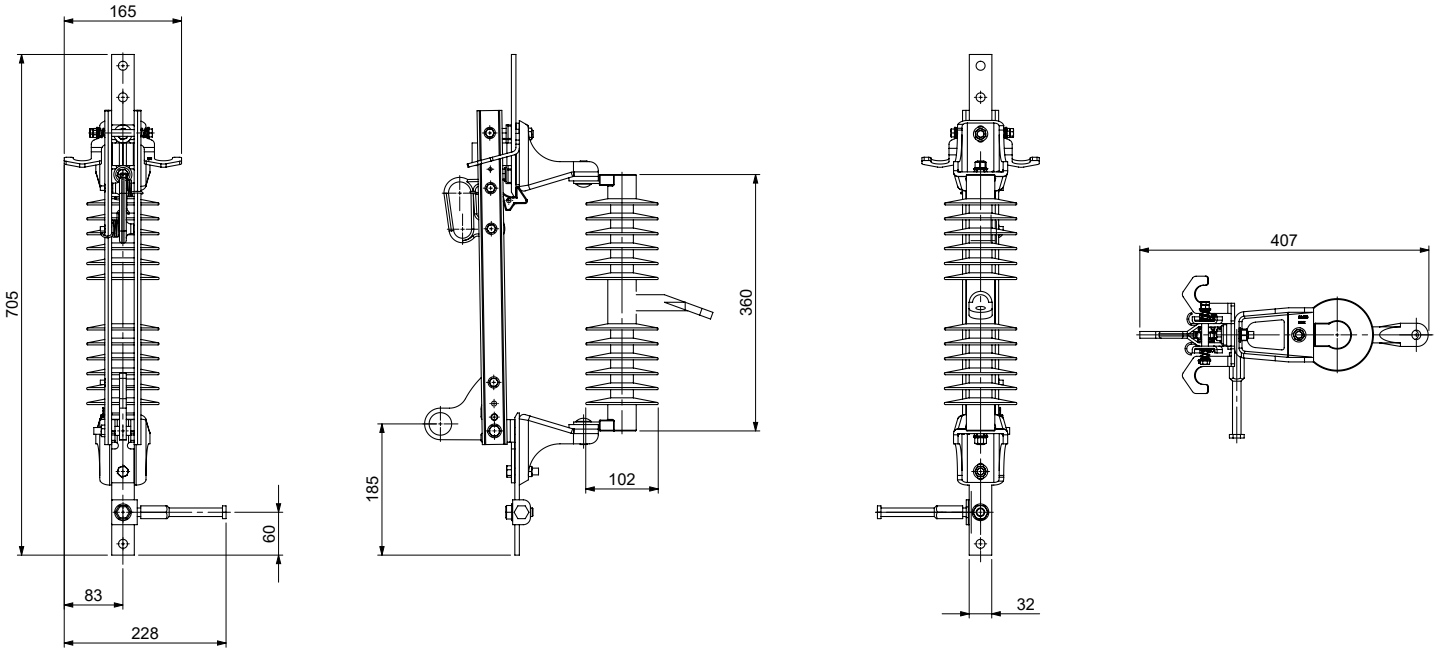

**DIMENSIONS - HDS900A-SI35S-150NBM**

