

# SMART<sup>®</sup> BAND FLEX

## - COMPOSITE BAND & BUCKLE SYSTEM

**Super Strong Strapping System – Safer | No Sharp Edges | Non-Conductive | Easier to Install**

Smart<sup>®</sup> Band is a 12.7mm (½") Band & Buckle system that once installed is stronger, tighter and maintains its tension longer than competitive products. The simplicity of the buckle design allows for ease of use & application.

Smart<sup>®</sup> Band is non-metallic and non-conductive it offers long-life and non-corrosive properties, making it the ideal alternative to many high grade stainless steel strapping solutions.

No matter what your application(s) – if you currently use stainless steel strap, you will be able to use Smart<sup>®</sup> Band as a replacement.



Scan the QR code to see just how easy it is to use the Smart<sup>®</sup> Band system.

### KEY FEATURES

- No sharp edges - operator and cable friendly.
- Tough, rugged and quick to fit
- Lightweight Acetal Material (Black)
- UV stable with high temperature resistance
- Corrosion resistant (no metal parts), non-magnetic and non-conductive
- Strength rated to 2100N (210kgf)
- Perfect for coaxial, fibre optic and all other communication and electrical cables
- Highly suited for applications where stainless steel strapping is currently used
- Glass Fibre Strands within band provide superior strength and retention
- Proprietary tool enables band to be tightened to a higher force than competitive products
- Meets requirements for installation in High-Risk PIM (Passive Intermodulation) Zones. It won't cause interference in wireless networks
- Meets or exceeds Telcordia TR-TSY-00789

## TECHNICAL SPECIFICATIONS

Material	Max Strength N (kgf)	Min Retention N (kgf)	Service Temp °C		Rec. Installation Temp °C	Flammability UL94	Chemical Resistance	Weathering & UV
			Min	Max				
POM	2100 (210)	400 (40)	-40	95	5	HB	Good	+20years

POM = Polyoxymethylene

## DIMENSIONS

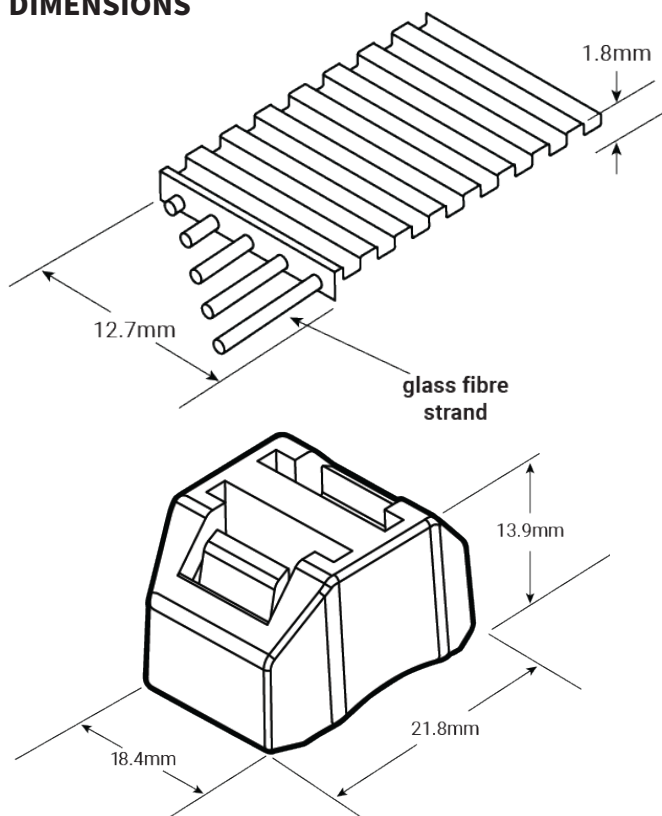

## INSTALLATION

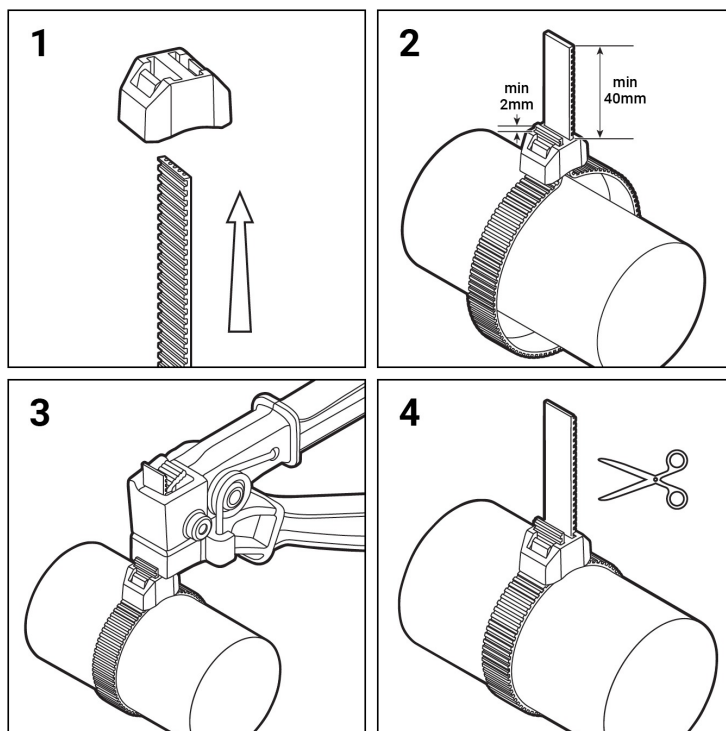

## ORDERING INFORMATION

CAT No.	Description	Pack Size
SB-BA-FX-1/2-POM-30M	12.7MM SMART BAND FLEX REEL 30M	30m
SB-BU-FX-1/2-LH-POM	12.7MM SMART BAND FLEX BUCKLES 100PACK	100pce
SM-FT-2000-13-FX	12.7MM SMART BAND FLEX MANUAL FITTING TOOL	1pce

Ed: 003, 07/24



TransNet NZ Ltd  
78 Cryers Road  
East Tamaki  
Auckland, 2013

0800 442 182 | +64 9 274 3340  
sales@transnet.co.nz | www.transnet.co.nz

