

HAUPA CABLE GLANDS

- METRIC NYLON GLANDS M12-M63

Cable glands protect electric equipment (for example switches or junction boxes) against mechanical treatment, dust and humidity, while also creating a firm connection between cable and box. Haupa cable glands are available with the IP rating IP68 (dust and waterproof).

Haupa cable glands are available in standard black for metric threads (light grey and PG threads available on special order).



TECHNICAL PROPERTIES:

- Temperature range: - 40°C to + 85°C
- Vibration protection: integrated anti-twist protection for vibration firm assembly
- Fire class: according to UL 94 V-2
- Protection category: IP68
- Material: polyamide 6.6
- Properties: integrated strain relief; easy to install RoHS-conform
- Delivery: completely assembled as shown

haupa[®]

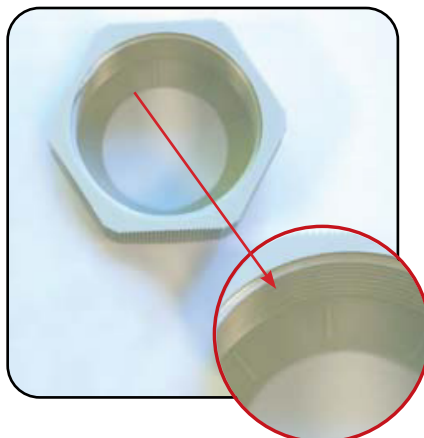

HAUPA NYLON CABLE GLANDS - METRIC



Cable glands IP68, metric (PG on special order), assembled with washer and lock nut

- **MATERIAL:** polyamide 6.6, (gland body: PA 6.6, halogen free, seal: TPR, halogen free, washer: PVC),
- **COLOUR:** black (light grey on special order)
- **TEMPERATURE RANGE:** - 40°C to + 85°C,
- **VIBRATION PROTECTION:** integrated anti- twist protection for vibration- firm assembly,
- **FIRE CLASS:** according to UL 94 V-2,
- **PROTECTION CATEGORY:** IP68,
- **PROPERTIES:** integrated strain relief; easy to install, RoHS- compliant, completely assembled as shown

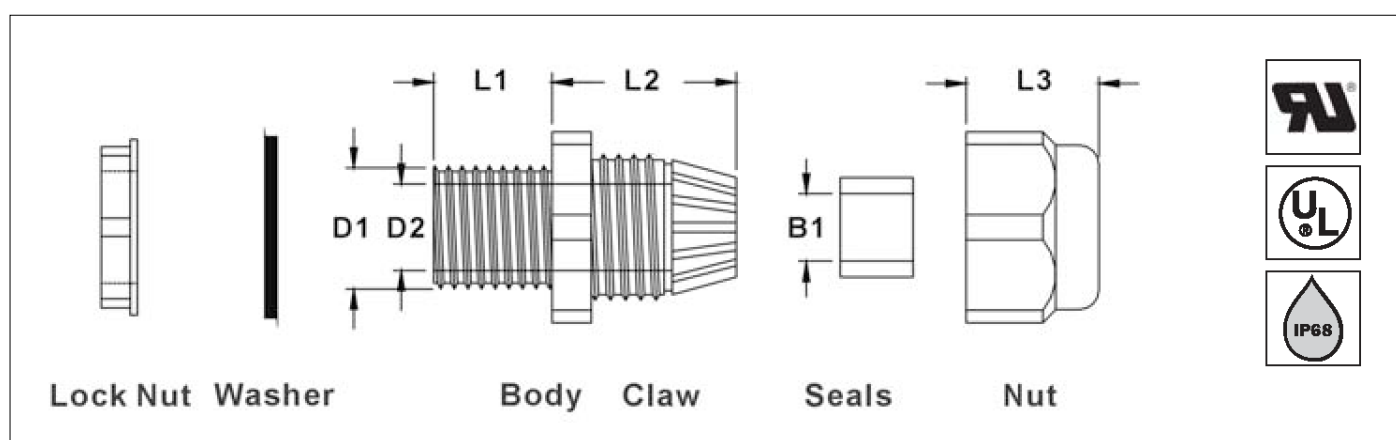

Product #	Cable Range	D1	D2	B1	L1	L2	L3	Washer size	Colour	Weight	Bag	Box
TNNG12	M12	3-6.5	12	8.3	6.9	7.9	19.6	13.6	15	Black	17.9	10 4250
TNNG16	M16	5-10	16	10.9	9.6	15.5	23.4	16.9	22	Black	17.9	10 1700
TNNG20	M20	10-14	20	15	14.8	15	28.5	18.5	27	Black	19.1	10 1190
TNNG25	M25	13-18	25	18.6	18.4	15.2	29.4	22.3	33	Black	18.8	10 680
TNNG32	M32	18-25	32	25	25	14.7	34.5	25.7	42	Black	15.8	10 34
TNNG40	M40	22-32	40	33.7	33.1	18.4	41.7	31.3	54	Black	21.3	5 230
TNNG50	M50	30-38	50	41.9	40	17.8	44.2	31.3	61	Black	16.0	5 160
TNNG63	M63	34-44	61	55	43.2	18.5	44.6	32.7	66	Black	12.5	5 120

TRANSNET NEW ZEALAND LTD

AUCKLAND

78 Cryers Road
East Tamaki
Auckland
NEW ZEALAND

Ph 0800 442 182
PO Box 39 383
Howick, Auckland

sales@transnet.co.nz

NEW ZEALAND

WELLINGTON

10 Petone Ave
Petone
Wellington
NEW ZEALAND

Ph 0800 442 182
PO Box 39 383
Howick, Auckland

sales@transnet.co.nz

NEW ZEALAND

TRANSNET TONGA

TONGA

Lakalakaimonu Multi Utility Complex
Taufa'ahau Road, Poutaha
Nuku'alofa
TONGA

Ph +67 627 939
PO Box 2932
Nuku'alofa

transnet@kalianet.to

TONGA



ISO 14001 CERTIFIED
ISO 14064-1 CERTIFIED
Toitū carbonreduce CERTIFIED